

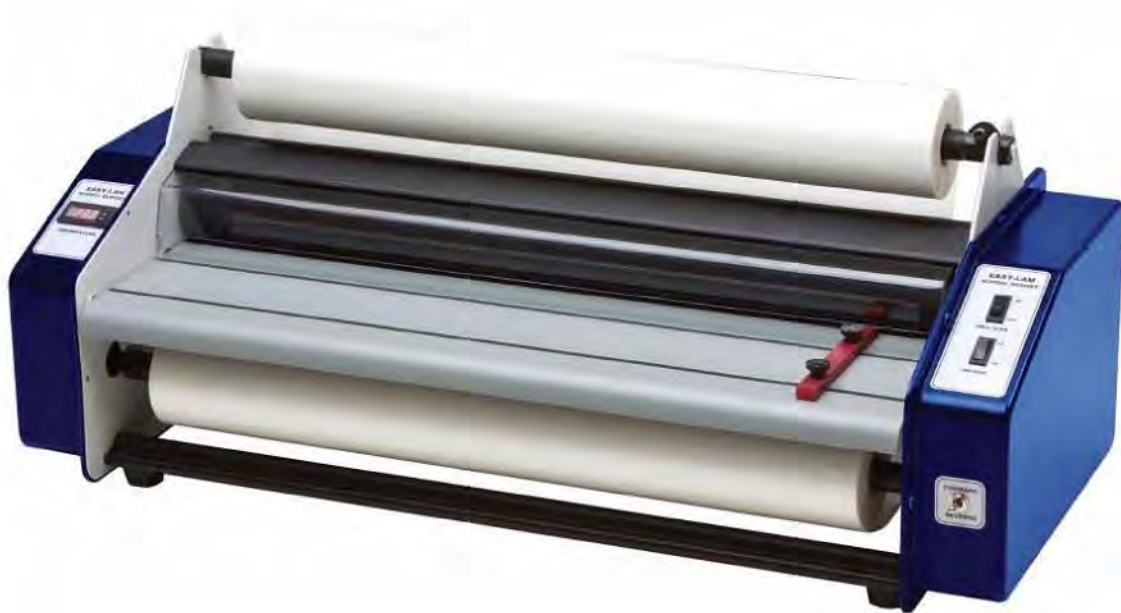

EZLam

School Budget

Roll Laminator



READ BEFORE OPERATING MACHINE
FAILURE TO LOAD FILM CORRECTLY WILL VOID ALL WARRANTIES



TABLE OF CONTENTS

Safety Messages and Electrical Safeguards	3-4
Introduction	5
Laminator Features.....	5
Specifications	5
Initial Set-up	6-7
Components.....	6-7
Heat Control.....	7
Operation	7-10
Loading Laminating Film.....	7
Threading Laminating Film.....	7-9
Adjusting Mandrel/Film Tension.....	9-10
Roller Temperature.....	10
Laminating	10-11
Troubleshooting	11-12
Maintenance	12-13
Cleaning Rollers.....	12-13
Removing Wrap Arounds.....	13
Warranty & Return Policy	14
Parts List	14



IMPORTANT SAFETY MESSAGES AND ELECTRICAL SAFEGUARDS

For your protection, do not connect the laminator to electrical power or attempt to operate it until you read these instructions completely. Keep these instructions in a convenient location for future reference. This instruction manual and labels affixed to the laminator are important safety messages. Read these messages carefully.

For your safety...

- * Keep hands, long hair, clothing, and other loose articles such as jewelry and ties, away from laminator's moving parts.
- * Save these Operating Instructions for later use.
- * Do not touch the heated rollers while the laminator power is turned on. Allow rollers to cool completely before touching.
- * Do not use the laminator for other than its intended purpose.
- * Place laminator on a sturdy cart, stand, or table. A laminator placed on an unstable surface may fall, causing serious bodily injury. Move laminator with caution. Quick stops, excessive force, or uneven floor surfaces may cause the laminator and cart to overturn.
- * Never override or attempt to defeat electrical or mechanical safety interlock devices.
- * Never insert objects or spill liquids in or on the laminator. They may contact dangerous voltage points or short out components that could result in fire or electrical shock.
- * The laminator should only be operated from the type of power source indicated in these Operating Instructions and on the data plate located on the rear panel of the laminator.
- * The three-pronged grounding plug is a safety feature and will only fit into a grounding-type power outlet. If you are unable to insert the plug into an outlet contact a qualified electrician to have a suitable outlet installed.
- * Do not leave the laminator power on overnight. Unplug the laminator at the end of the day.
- * Unplug the laminator before moving it or when it is not in use for an extended period of time as a precaution against the possibility of an internal malfunction that could create a fire hazard.
- * Do not operate the laminator with a damaged power supply cord or plug, or after it malfunctions or has been damaged in any manner.
- * Keep the power cord away from hot or wet surfaces.



- * Do not overload electrical outlets beyond their capacity as this can result in fire or electrical shock. This unit is rated at 15 amps and should be the only item plugged into a 15 or 12 amp branch circuit. When connected to a 20 amp branch circuit any items in addition to the EZSB must not exceed 4 amps.
- * Adjust only those controls that are specified in these Operating Instructions.
- * Do not attempt to service or repair the laminator yourself. Unplug the laminator from the electrical outlet and contact an authorized service representative under any of the following conditions:
 - When the power supply cord or plug is damaged or frayed.
 - If liquid has been spilled into the laminator or it has been exposed to water.
 - If the laminator has been subjected to excessive jarring through being dropped or bumped.
 - If the laminator does not operate normally when following the operating instructions.



INTRODUCTION

Congratulations on your purchase of the new EZLam School Budget (EZSB) Roll Laminator. This unit is designed to provide years of trouble-free service.

The EZSB will accept rolls of laminating film up to 27" wide in both 1.5 and 3 mil thicknesses.

Your EZSB is preset at the factory for most applications so any adjustments should be minor. A digital heat controller provides continual indication of the heated roller temperature and may be adjusted as needed.

Laminator Standard Features...

- * Preset laminating roller pressure and speed require no adjustment.
- * Feed table with adjustable guide.
- * Digital heat controller for monitoring temperature.
- * Silicon laminating rollers for exceptional clarity.
- * Laminating film widths up to 27".
- * Total thickness up to 70 mils (laminates plus paper).

SPECIFICATIONS

Plastic Width	27" (68.6cm)
Plastic Thickness	1.5 mil and 3 mil
Maximum Roll Length	1.5 mil - 1,000 feet (304.8 meters) 3 mil - 500 feet (152.4 meters)
Dimensions	15" (38.0 cm) L x 35" (88.9) W x 13.5" (34.3 cm) H
Speed	3.5' feet per minute (1.1m/minute)
Net weight	66lbs. (28 kg)
Power Requirements	120VAC, 60Hz, 1440 watts



INITIAL SETUP

Unpacking and assembly...

Before unpacking the unit, inspect the shipping container for signs of damage. Notify the carrier and your dealer immediately if any damage is noted. **Make sure to keep the box and packaging.**

CAUTION!

The laminator, without the feed table weighs approximately 60 lbs. Use two people when removing the laminator from the shipping container.

Components...

The figure below shows the location of the major components and controls of the EZSB. You should become familiar with these before operating the laminator.



FWD/REV Switch: This three position (FWD/OFF/REV) switch controls power to the Laminating Rollers. If the switch is pressed to the FWD position the rollers move forward, pulling the plastic film and laminated material past the Heat Shoes.

When this switch is pressed to the REV position the rollers move in the reverse direction. This is useful for clearing film from the rollers.

Heater Switch: This switch turns on power to the top and bottom heated rollers and turns on the temperature controller.



Motor Master Switch: Cuts power to FWD/REV Switch.

Allen Key: Use to adjust film tension.

Heat Control

Your new EZSB has a digital heat controller. Users can easily adjust the set temperature for the rollers to achieve the best quality lamination. The controller has been calibrated to accurately display the roller temperature in the laminating range.

The heater switch on the right side cover activates the controller. When the switch is turned on the controller will flash a two letter code and then display the roller temperature. When cold, the temperature displayed on the controllers may be different than the actual ambient temperature to account for correction in the higher temperature range. When the heater switch is turned on, the controller will send power to the heaters, provided the Set Temperature is higher than ambient temperature. (For safety reasons, this machine was shipped with the Set Temperature at 260°F).

When power is being sent to the heaters the controller will illuminate a small red indicator light in the lower right hand corner of the display. The light goes out when the Set Temperature is reached. Power to the heaters will cycle when the roller temperature falls below the Set Temperature during lamination or while sitting idle.

OPERATION

This section describes the operation of your EZSB. This laminator is designed for all widths of plastic up to 27". However, if narrower widths are used the rollers must be cleaned before using a wider roll. Refer to the MAINTENANCE section for cleaning instructions.

Loading Laminating Film onto Mandrels...

Slide the film onto the mandrel making sure that the mandrel spring is in position to compress properly when the film is pushed onto the mandrel. *Remove the film in the same direction.* Use the lines to center the two rolls on one another.

Threading Laminating Film...

These instructions apply to poly-in film rolls (shiny side out, dull side in)

1. For the top supply roll place the mandrel ends into the slots in the top of the laminator. If you are facing the front of the laminator the film should unwind toward you from the bottom of the roll as in Figure 3 on the next page.

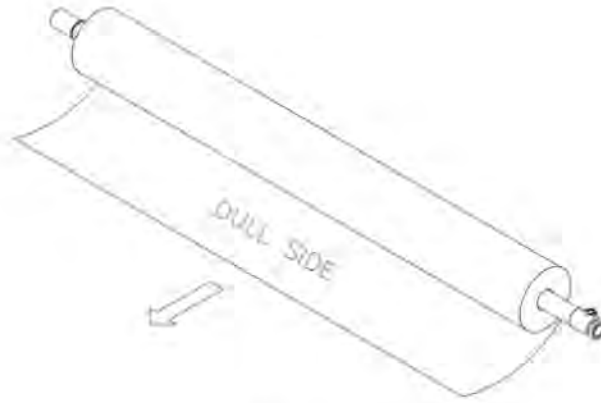

Figure 3

2. Pull 6"-12" of film from the top roll. Pass the film under the idler bar and over the roller. Make sure the shiny side of the film is against the roller.
3. For the bottom supply roll, remove the feed table. Place the mandrel ends into position in the lower mandrel holder slots. Return the feed table to its proper position before operating the laminator. If you are at the front of the laminator the film should unwind away from you at the bottom of the roll as in Figure 4 below.

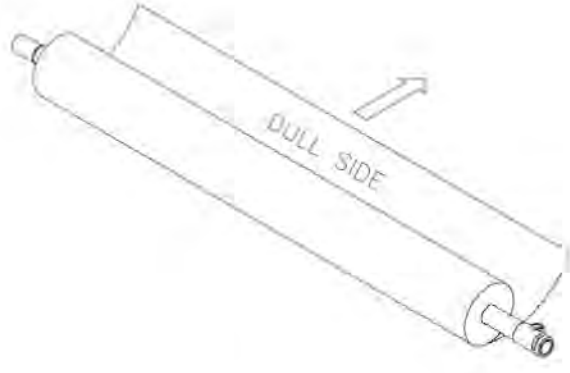

Figure 4

4. Pull 6"-12" of film from the bottom roll. Pass it under the lower idler bar and drape the film from the bottom roll over the film from the top roll. Since the rollers are hot the bottom film will adhere to the top film. See Figure 5 below.

Note: The shiny side of the film must always go against the rollers.

Caution:
The rollers reach a temperature of up to 300°F.
Do not touch the surface of the heated rollers.

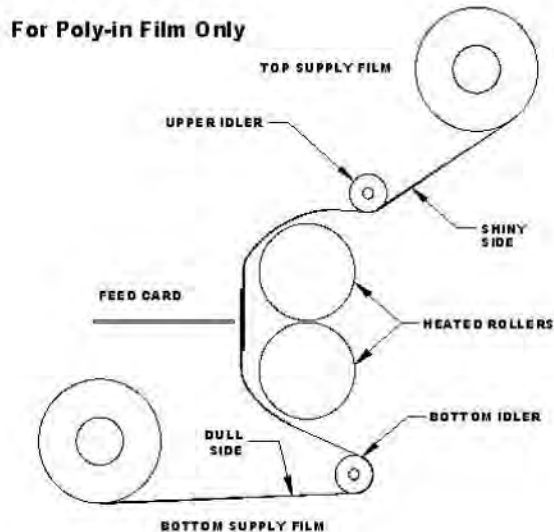

Figure 5

5. Turn the Motor switch to FWD to start the Laminating and Pull Rollers.
6. Feed a piece of thin cardboard about 10" x 25" against the film so that it is centered between the two Heat Shoes. Push the cardboard and film into the Laminating Rollers. See figure 5.
7. When the feed card has completely exited the Pull Rollers at the rear of the laminator turn the Motor Switch off.
8. Insert the Feed Table onto the studs located on each side of the unit, between the rollers.
9. If you are not ready to laminate, turn the Heat Switch to the down position (off).

Adjusting Mandrel/Film Tension...

Each type of laminating film has different characteristics and may require laminator adjustment. The tension should be set so that the film moves over the rollers without dimples as the film enters the laminator. Best results are obtained if tension adjustments are made while the unit is at operating temperature. If any adjustments are required use the following procedure:

1. Press the Motor switch to on.
2. Locate Allen Key and insert into capscrew on the right side of the mandrel. Turn the screw to adjust the tension (clockwise to increase, counter clockwise to decrease) until the film passes over the roller without wrinkles and the web between the laminating and pull rollers is tight.

Note: This adjustment requires only a few degrees of turn. If the screw is turned too far clockwise, you may stall the drive motor.





4. Repeat for Bottom Supply Mandrel.
5. If you are not ready to laminate, turn the Motor switch off and Heat Switches off.

Setting Roller Temperature...

The laminator temperature should be adjusted according to the film thickness and the item being laminated. See Table 1 on the next page for recommended temperature settings. *Keep in mind that the temperatures listed are approximate and different brands of laminating film may require different temperatures.*

1. Turn the Heater switch on.
2. Adjust using digital heat controller. To set the temperature press and hold the appropriate arrow until the desired temperature is reached. Then press both arrows to save the setting.

Material	Temperature Range
1.5 mil (.0015")	270°F – 280°F
3 mil (.003")	245°F - 255°F

Table

LAMINATING

1. Be sure the heaters have been turned on and are at the proper temperature. Be sure the film has been properly threaded.

Caution:

Do not allow the temperature to exceed 300°F as this could cause the silicone coating to separate from the roller core on the heated rollers and will void your warranty.

2. Adjust the Paper Guide on the Feed Table so that the right edge of the item will enter the laminator at the desired position.
3. Press the Motor switch to the ON position. The film will begin moving through the laminator.
4. After clear laminating film exits the Pull Rollers at the rear of the machine you may slide the first item to be laminated into the laminator with the right edge along the Paper Guide.

Note: You may want to run a test lamination first as any item that passes between the rollers will be laminated and cannot be recovered until it exits the rear of the laminator.

5. Additional items may be fed in sequence, keeping enough distance between sheets for trimming.
6. After the last item has exited the Pull Rollers, turn the Motor switch off.



7. Use the Zippy Cutter to cut across the film to remove the laminated items from the unit.

TROUBLESHOOTING

The following guide will assist you with most problems that may be encountered when laminating.

PROBLEM: *Laminator is inoperative. Motor does not turn, machine does not heat.*

ACTION: Unit may be unplugged. Connect power supply. Ensure that the circuit breaker has not tripped Fuse may have blown. Replace fuse (rear next to power cord) with 15 amp BUSS (MDA-15) for standard units.

PROBLEM: *Laminator heats but motor does not run*

ACTION: Ensure all motor switches are in the ON position. Check that FWD/REV switch is up. (FWD) Change motor fuse with .75 amp fast blow fuse.

PROBLEM: *Laminator blows fuses often.*

ACTION: Ensure machine is running on a dedicated circuit. Do not exceed maximum material thickness. Reduce supply mandrel tension.

PROBLEM: *Laminating film and item being laminated move through laminator erratically.*

ACTION: Check thickness of item to be laminated. Maximum thickness is 1/16" (1.6mm). Clean rollers of residual adhesive. Refer to MAINTENANCE section for cleaning instructions.

PROBLEM: *Plastic is not bonding to the item or to itself at the edges.*

ACTION: Make sure rollers are at proper operating temperature and have had time to warm up. See Table 1 for the suggested temperature ranges. (ensure you are using quality film). If the temperature is set correctly and the film is not bonding then the film is most likely bad.

PROBLEM: *Wrinkles on laminated item running parallel with supply rolls.*

ACTION: Increase film mandrel tension on top and/or bottom supply rolls; only small amounts between tests. Reduce roller temperature.

PROBLEM: *Stretch lines appear on laminated items running parallel with the outside edges.*

ACTION: Increase supply mandrel tension on top and/or bottom supply rolls. Reduce roller temperature. Clean rollers of residual adhesive. See MAINTENANCE section for cleaning instructions.



PROBLEM: *Blistering of the film appears over the item or along the edge.*

ACTION: Reduce roller temperature. Clean laminating rollers. See MAINTENANCE section for cleaning instructions. There may be moisture in the paper you are laminating. Store paper in a dry place and be sure that any ink is thoroughly dry before laminating.

PROBLEM: *Laminated material curls after leaving pull rollers.*

ACTION: Adjust tension. If laminated item curls upwards, reduce top mandrel tension. If item curls downward, reduce bottom mandrel tension. Clean rollers of residual adhesive as it may be causing "drag" on one side. Refer to MAINTENANCE section for cleaning instructions.

PROBLEM: *Machine smokes and emits fumes.*

ACTION: Reduce temperature. Never exceed 300°F, unplug machine and thoroughly clean rollers.

PROBLEM: *Temperature inaccurate, machine overheating.*

ACTION: Ensure temperature sensor (behind top roller) is in firm contact with roller. See diagram on next page.

MAINTENANCE

This section contains instructions for cleaning and maintaining your laminator. These procedures should be performed at regular intervals to help ensure the trouble-free operation of your laminator.

Caution:

Before performing any maintenance on your laminator first disconnect the power supply. Hazardous voltages are present when the side panels are removed.

Cleaning the Laminating Rollers...

The Laminating Rollers should be cleaned of any residual adhesive whenever the film does not pass smoothly over their surfaces. Be cautious with sharp objects near the rollers.

1. Allow the rollers to cool.
2. Remove the Feed Table by lifting and pulling it toward you to expose the rollers.
3. Cut the plastic film from the supply rolls and where it exits the rollers. Pull the film toward you and away from the rollers.



4. Lift the film away from the rollers. Turn the power on and hold the Motor Drive switch in the REV position while pulling the film forward toward you (from the front of the laminator).
5. Use a soft cloth moistened with denatured alcohol to remove any residue from the surface of the Laminating Rollers.
6. Allow the Laminating Rollers to dry before re-threading the film.

Removing Wrap-arounds...

When laminating with thinner gauges of film, there is the possibility of the film wrapping around the Pull Rollers. Use the same procedure for **Cleaning the Laminating Rollers** in order to remove a wrap-around. You should remove any wrap-arounds that occur as soon as possible. If the film is allowed to cool while wrapped around the rollers it may be more difficult to remove and the heaters may have to be turned on to loosen the film.

CAUTION: The rollers are hot! Use caution when cleaning the rollers or when removing wrap-arounds. Be careful with sharp objects, cutting a rubber roller will ruin it and result in a void of warranty.

NOTE: Ensure temperature sensor is touching roller after experiencing a wrap-around.

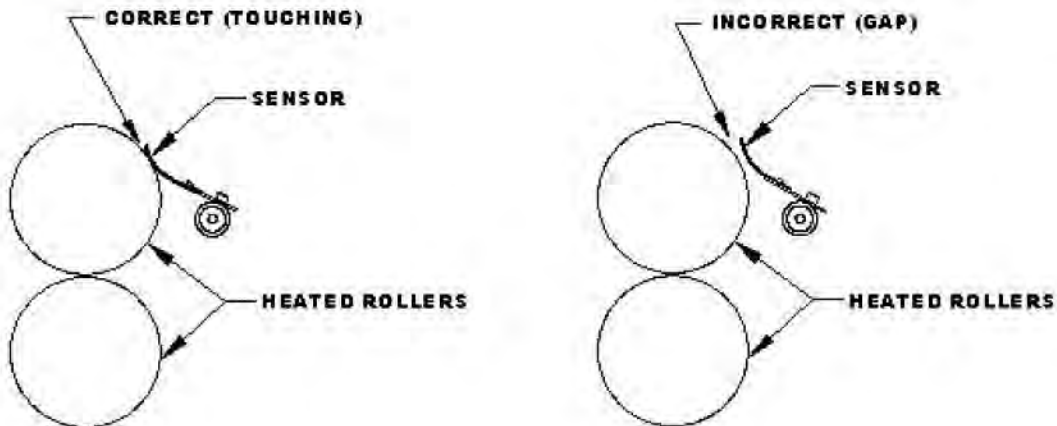



WARRANTY AND RETURN POLICY

Warranty

Your laminator is warranted to be free of defects in material and workmanship for a period of 1 year from the date of original purchase. In the event of a defect in material or workmanship, the manufacturer or its authorized dealer, will repair or replace (at their option) the laminator. This does not cover rollers that have been damaged due to improper cleaning. The manufacturer makes no other warranty stated or implied except as stated above.

Return Policy

If your laminator is not operating properly, first review the Operating Instructions and Troubleshooting Guide. If the malfunction cannot be corrected, contact your local dealer for instructions. Be sure to have your machine serial number and date of purchase handy. If the laminator must be returned to the dealer, *proper packaging and freight charges are your responsibility*. Shipping damage as a result of improper packaging is not covered under the terms of this warranty.

PARTS LIST

<u>Item</u>	<u>Part #</u>	<u>Description</u>	<u>Qty</u>
1	11489	Switch 20 amp (heat)	1
2	690301	Heated roller	1
3	1441	Roller, E-Z bottom	1
4	1445	Roller, E-Z top (crown)	1
5	3001	Core Gripper, EZ Mandrel	2
6	10103	Table, Feed	1
7	11327	Fuse, 15A Fast-Blow (heat)	1
8	11540	Fuse Holder, HTB-38I (motor)	1
9	11625	Fuse Holder, (30A) Power	1
10	690300	Tubular Heater	2
11	690312	Motor EZSB	1
12	1395	Cord, Power 14-3	1
13	10371	Sprocket, 25B21,.625 Bore	1
14	10232	Switch, Motor Reverse EZII	1
15	10349	Rectifier, EZII	1
16	532	Switch, On-Off (motor)	1
17	11532	Fuse ¾ Amp Fast Blow	1
18	11596	Control, Heat, Mightylam	1
19	11597	Sensor, Kapton	1
20	690316	Nylon Stud	4
21	10322	Guide, Feed Table, EZII	1
22	690317	Sprocket, EZSB Motor	1
23	690318	Sprocket, EZSB Roller	1
24	690319	Chain, EZSB 25HMRB X 75P	1